

# Sheet Resistance & Resistivity Measuring System

4-Point probe system for wafer

Model **CMT-SR5000**

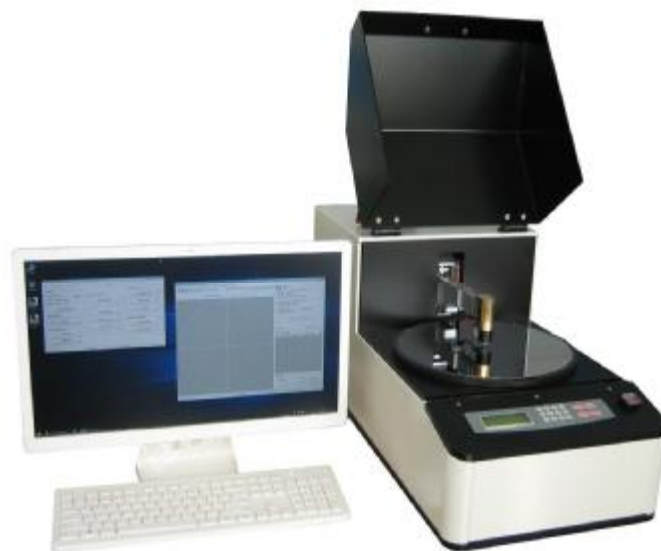

**AiT Co., Ltd.**  
Advanced Instrument Technology

103-407 Digital Empire 2, 88 Sinwon-ro, Yeongtong, Suwon, Gyeonggi, 16681 Korea  
Tel: +82-31-695-7166 Fax: +82-31-695-7169 [www.fpp.co.kr](http://www.fpp.co.kr)

## **1. Introduction**

The CMT-SR5000 is a full automatic system to measure Sheet resistance and Resistivity for max. 300mm wafer or 210x210mm square sample, etc.

This system can be operated by itself (stand-alone), furthermore, perfect remote control is available by using a PC and exclusive software, and it provides a various data analysis functions.

## **2. Features**

- Ø X, Y, Z axis full automatic system.
- Ø Automatic & Manual measurement range selection.
- Ø Up to 300mm wafer or 210x210mm square sample capability.
- Ø Single and Dual measurement method.
- Ø Temperature sensing sensor for Temperature correction factor. (Option)
- Ø Data analysis functions - 2D, 3D map, Data map, etc.
- Ø ASTM, SEMI standard measurement mode by software.

## **3. Configuration**

The system consists of following components.

- Ø 4-point probe head unit.
- Ø Automatic contact unit. (Z axis)
- Ø Rotation sample stage (X axis) & Straight-line motion arm. (Y axis)
- Ø Temperature sensing sensor for Temperature correction factor. (Option)
- Ø Remote control communication port. (USB port)
- Ø Vacuum input port. (one-touch fitting connector)
- Ø Operating Software. (Microsoft Windows XP SP3 / 7 Ver.)
- Ø Standard accessories
  - Power cable
  - Remote control communication cable. (USB cable)
  - Operating & service manual.

## 4. Specifications

### Ø Sheet resistance measurement

- Measuring method : Contacted by four point probe
- Measuring range : 1 mohm/sq ~ 2 Mohm/sq

### Ø Resistivity measurement

- Measuring method : Contacted by four point probe  
(Input thickness)
- Measuring range : 10.0  $\mu$  ohm·cm ~ 200.0 Kohm·cm

### Ø Current Source

- Range : 5nA to 160mA

### Ø Measurement Accuracy

- $\pm 0.5$  % (Precision Resistor)

### Ø Measurement Repeatability ( $2\sigma$ )

- $\pm 0.15$  % (Precision Resistor)

### Ø Measurement time : Approx. $2 \pm 1$ sec/point

### Ø Four point probe (JANDEL ENG.)

- Spacing between tips : 0.635mm, 1.0mm, 1.27mm, 1.591mm  
Tolerance  $\pm 0.01$  mm
- Load on each tips : fixed between 10g and 250g
- Tip radius : 12.5, 25, 40, 100, 150, 200, 300, 500 microns
- Tip material : TC(tungsten carbide), 50% Osmium alloy

### Ref)

- A type : 40 micron, 100g, 1mm
- B type : 100 micron, 100g, 1mm
- C type : 200 micron, 100g, 1mm
- D type : 500 micron, 100g, 1mm
- E type : 40 micron, 200g, 1.59mm

## 5. Measuring specimen

- Ø Maximum 300mm wafer or 210x210mm square sample.

## 6. Outside dimensions

- Ø 360mm(W) x 830mm(D) x 400mm(H)

Note) The outside dimensions take to change by maker in case of need.

## **7. Operating software**

- Ø General Personal computer.
- Ø Operating system : Microsoft Windows XP SP3 / 7 Ver.
- Ø Remote control communication method : USB port
- Ø Measurement Data management
  - Data save & load, export.
  - NFS transfer via LAN
- Ø Various Measurement Mode
  - Recipe measurement : Recipe point designation by user.
  - Standard measurement : ASTM & SEMI mode.
  - Pattern measurement : 49, 81, 121, 225 point, etc.
  - Step measurement : Point interval designation by user.
  - Manual measurement : Point by inputting coordinate values
- Ø Data Analysis functions : 2D, 3D map, Data map, Statistics, etc.
- Ø User management
  - User register, selectable security level user, Login, etc.

## **8. Operating environment**

- Ø Temperature range : 23°C ± 1°C
- Ø Relative humidity : 30% ~ 70%
- Ø Avoid placing the system near a source of RFI, vibration and sources of gas.
- Ø Avoid large changes in temperature.

## **9. Utility requirements**

- Ø Power requirements (1 Line)
  - Line voltage : AC 220V or 110V ± 10%
  - Electric power : 100W, 500mA
  - Line frequency : 50/60 Hz
- Ø Vacuum requirements (1 Line)
  - Vacuum : About 200mmHg.
  - Connection method : Urethane tube Dia. 4mm. (outside diameter)

## 10. Measuring flow

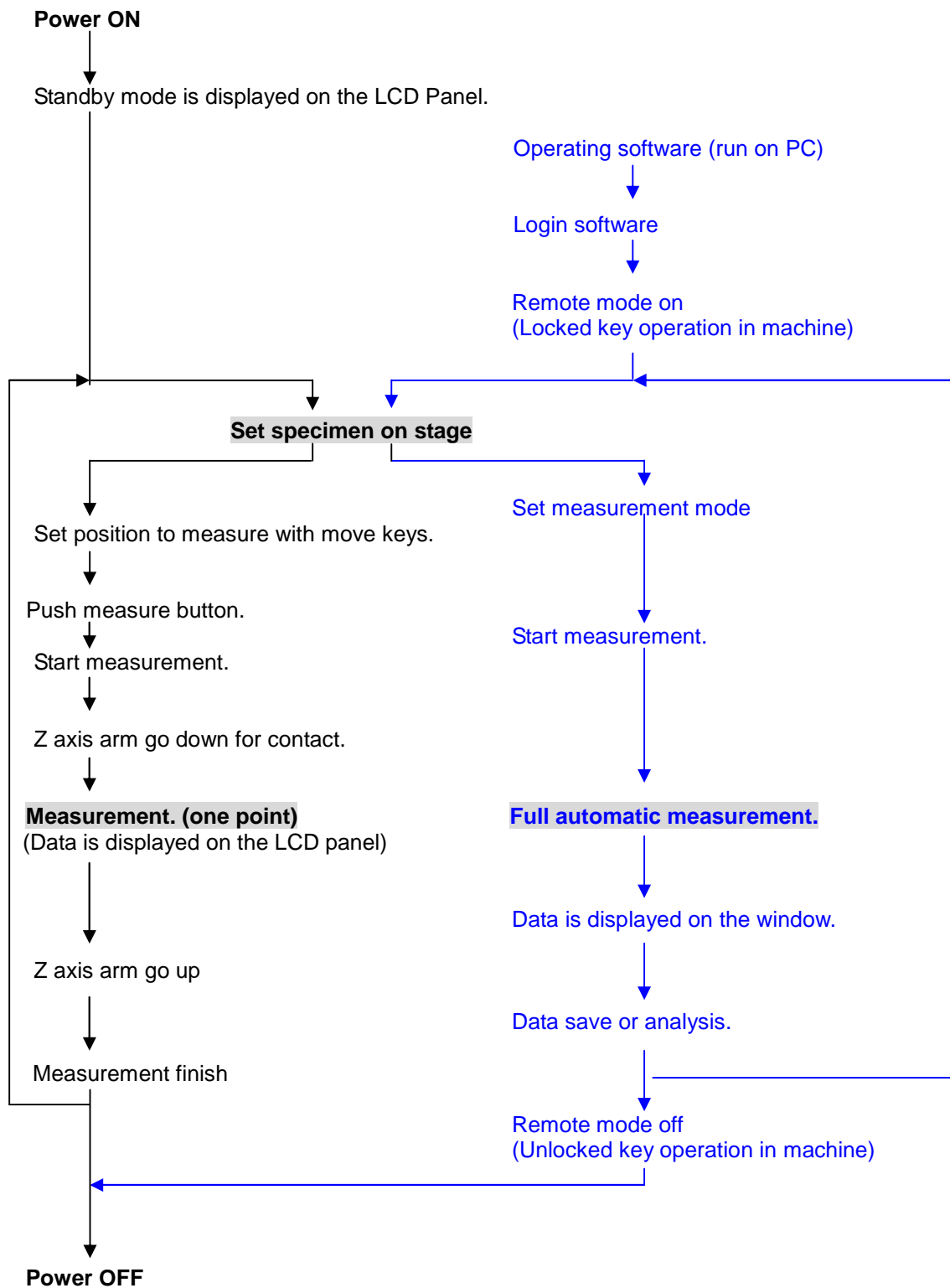

### Note)

- Black color (left) is flow for standalone operation.
- Blue color (right) is flow for remote controls by software.

### 11. System construction diagram

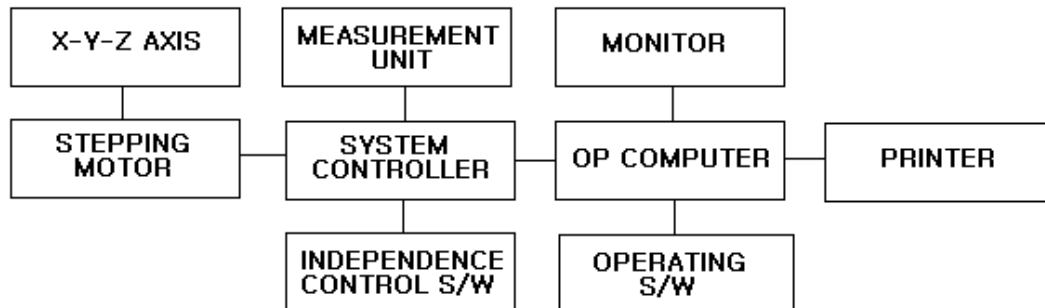

### 12. Measurement construction diagram

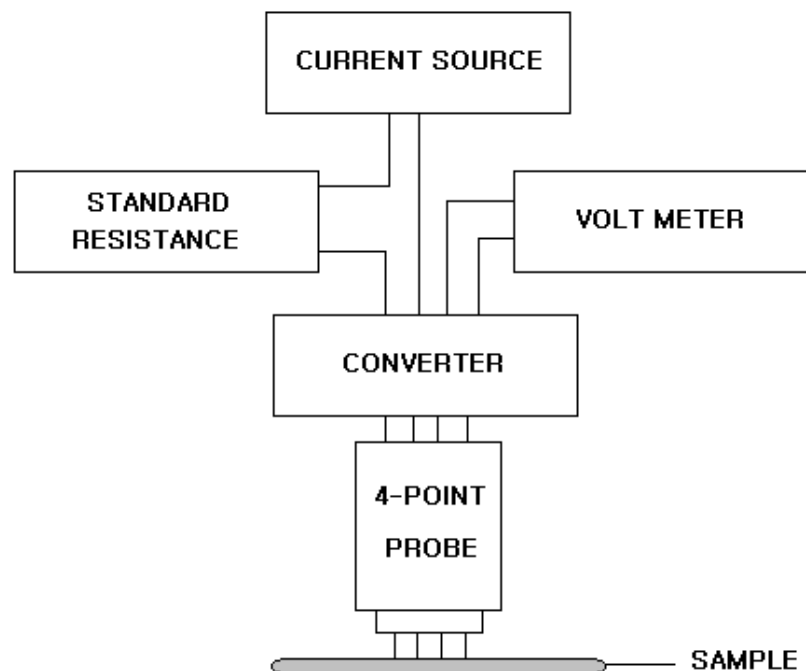

### 13. 2D(Contour) & 3D Map (example)

